

Boise State University Graduates to Largest National Education VoIP Deployment with tw telecom IP-based Solution



THE COMPANY

Boise State University

INDUSTRY

Education

EMPLOYEES

2,200

BUSINESS RESULTS

- **VoIP-enabled solution cut call expenses by 50 percent**
- **Eliminated six gateway devices via direct-connect SIP trunk**
- **Simplified network to significantly reduce administration effort**
- **Metro Ethernet upgraded remote campus user status to real time application access**

COMMUNICATIONS APPLICATIONS

- **Voice over IP implementation**
- **Economical long distance calling**
- **Inter-facility voice/data/video connectivity**



The Challenge

Several years ago, Boise State University IT managers looked to the future of communications technology. They reviewed their expenditures. They talked about their dealings with their communications vendor. And in the end, they decided to convert their copper-wire based voice network to a fiber-based, voice over Internet protocol (VoIP) network.

It wasn't an easy journey. At the time, their vendor was a monopolistic-minded incumbent local exchange carrier (ILEC). According to Brian McDevitt, manager of telephone network services, for the University, "It was always frustrating because it was such a chore to get any customer service out of them."

So motivated by poor service, the desire to deploy productivity-enhancing technology and trim expenses and effectively connect the school's three main campuses, Boise State managers issued an RFP. In the end, **tw telecom** won the bid to implement a plan to replace 1,000 copper lines with a fiber solution.

"**tw telecom** helped us achieve our goal of bringing all service on campus onto fiber," explained McDevitt. We saw a need to be on metro fiber to reduce prices and scale circuits effectively to pace our fast growth."

Later, Boise State managers decided to simplify their network further by taking the next evolutionary VoIP step. They issued an RFP for a Session Initiation Protocol (SIP) trunk that would connect directly to their VoIP PBX. Again **tw telecom** won the competitive bid.

Fueled by the new services, Boise State's VoIP deployment had grown to 14,000 DIDs and 4,000 handsets, making it the largest nationwide among Universities, 65th overall nationwide and 145th worldwide.

About tw telecom

tw telecom delivers the most advanced telecommunications solutions on the market to a wide spectrum of businesses and organizations across the United States. Since 1993, we have built a legacy of success through exceptional customer care, remarkable products and powerful networks. These strengths enable us to deliver scalable solutions that help customers improve their business metrics. For more information, please visit www.twtelecom.com.

RELATED SOLUTIONS/ TECHNOLOGIES

- Cisco CallManager IP PBX server-based application

TW TELECOM SOLUTIONS

- SIP Trunk (SIP IP Trunking)
- Metro Ethernet Service (Native LAN Service)

The Solution

Services: Boise State initially deployed tw telecom's Metro Ethernet service (Native LAN). The two 100 Mbps pipes linked the University's main and two remote Canyon County and Boise West campuses. These moved the network from divergent voice/data communications to converged Ethernet circuits which carry data, video and voice traffic.

Later, Boise State network engineers worked with **tw telecom** experts to replace eight T1s with a single 20 Mbps Quality-of-Service-enabled SIP trunk at the main campus. The SIP service connects directly to the University's Cisco CallManager VoIP PBX system and provides PSTN termination for unlimited local calls. To meet business continuity objectives, McDevitt runs CallManager on three clustered servers across campus.

The Value to the Business

Financial Benefits

Boise State managers leveraged the new technology to good effect. "We figure the new solution will be about half the cost of what we paid previously," explained McDevitt. "That's possible in part because the SIP trunk allows us to access on-net long-distance **tw telecom** nodes for free. Those are important considerations for a state-funded university."

By connecting directly to Boise State's network, the SIP trunk enabled the retirement of six gateways formerly used to connect to T1 digital service.

"Not only did that simplify our network, it gave us savings in administration and maintenance costs," said McDevitt.

The easier-to-administrate VoIP phone system contributed to McDevitt's ability to hold the line on headcounts too. That's in spite of significant growth in recent years that has doubled the size of the University's phone network.

Business Benefits

The metro Ethernet solution allowed McDevitt's team to economically and efficiently connect the school's Main, West and Canyon County campuses. This eliminated the need to use costly tie lines or the related hardware and maintenance that would have been required with an alternative solution.

Shortly after moving to a VoIP implementation, Boise State technicians began running a single line to desktops versus the two-wire harnesses they ran before. "Being able to lay one data cable to the desktop and split it for phone service really reduces our overhead costs," stated McDevitt. "We can turn up new stations quicker and more efficiently."

In referring to the University's deployment of **tw telecom**'s metro Ethernet service, McDevitt said, "Our remote locations are about 15 miles apart. By replacing T1s with the 100 Mbps service we were able to upgrade users at remote sites to real time status."

"The **tw telecom** SIP Trunk is a key element of our VoIP implementation. It is highly scalable, interoperates with our Cisco CallManager application, and will substantially cut our costs. We believe SIP technology will revolutionize business communications the way VoIP has changed the residential landscape."

Brian McDevitt

Manager of Telephone

Network Services

Boise State University

From an employee/student productivity perspective, McDevitt is bullish on VoIP's future potential. "We're looking forward to the next generation of applications. For example, students, faculty and administrators will eventually be able to click a link on a website to be connected automatically. When you multiply the seconds of time savings that gives you by the thousands of times it would be used daily, it adds up."

Another VoIP benefit has been easing the burden on the school's help desk. The new phones use intuitive web-based interfaces that replace arcane phone customization button sequences of old.

Technology Benefits

The new solution enabled the IT team to converge their voice and Internet traffic. This eliminated the need to manage, maintain and update separate voice and data networks and their related infrastructure.

According to McDevitt, the SIP implementation simplified the administration of his networks. "The converged voice and data network means we only need to worry about a single connection. From a personnel skill-set perspective, that means I can run voice and data services with people experienced with data networks."

Additionally, by providing an IP handoff, the Boise State IT staff was able to fully utilize their IP PBX LAN infrastructure to support local calling and inter-office calling for faculty, staff and students.

Since migrating to **tw telecom's** fiber, Boise State has upgraded to greater bandwidth, scalability and business-class service. Specifically, the SIP trunk service scales from two to hundreds of Mbps capacity. And McDevitt describes the service as "clearer with less static than the old solution."

Another service advantage has been reduced downtime. Before, if a T1 had a bad channel it had to be configured out of the CO. "When you change to SIP trunking everything becomes software controllable," stated McDevitt. "We can compress channels, alter data streams and do a lot of other things. It's much more configurable by us. We could do almost nothing with the old T1s."

From a network topology standpoint, the SIP trunk deployment eliminated potential points of failure. "We retired six T1 gateway devices we no longer needed," explained McDevitt. "We just dropped the SIP line onto our main university routers and were good to go."

Before

Legacy Voice Deployment with PRLs and Separate IP access for Internet

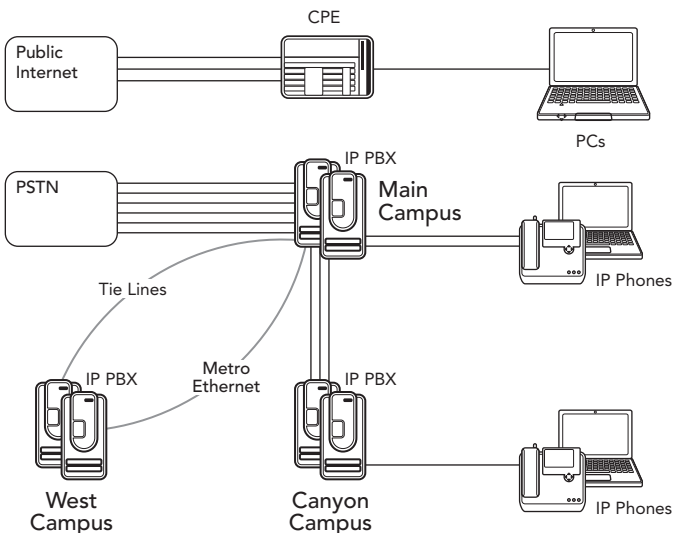

After

SIP IP Trunks Deployment with Converged VoIP and Internet across Metro Ethernet.

SIP IP Trunking provides unlimited local calling (PSTN Terminator) and converged Internet access

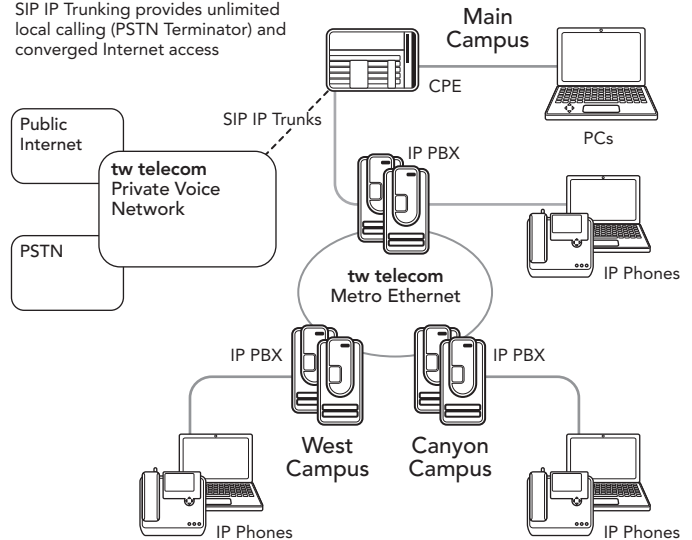

The tw telecom Experience

tw telecom put to rest customer service issues for Boise State managers. "It's been very refreshing to have a sales person continue to follow up with me after the sale," explained McDevitt. "There was no drop off in responsiveness to our needs or to any issues. Unlike our former provider, I talk to people at the CO down the street if there's a problem instead of some guy in Denver."

As for the SIP deployment, "The process as been great so far. tw telecom brought in industry experts to make sure this new technology goes in perfectly the first time. The project schedule was well planned and it's been pleasant dealing with their management, technicians and experts."

Boise State University

Boise State University is the largest institution of higher education in Idaho with about 18,600 students and 2,200 faculty and staff. More than 190 undergraduate, graduate, doctoral and technical degrees are offered within eight colleges. A metropolitan university located in the capital city, Boise State is committed to life-enhancing research, teaching excellence and public service. www.boisestate.edu